



**Innovative Power Transmission**

# **ELCO-Coupling**

**Flexible Compression Sleeve Coupling**

# Type

## Flexible Compression Sleeve Coupling

### 1 Type

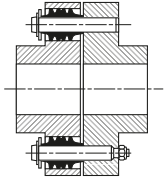

**Type – N** Page 10  
Standard; the transmitting elements arranged at one side

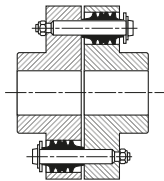

**Type – W** Page 10  
The transmitting elements inversely arranged

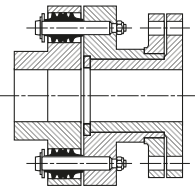

**Type – B** Page 14  
With shear pins

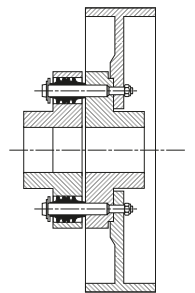

**Type – S** Page 16  
Standard with brake drum or brake disc

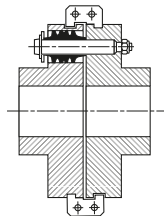

**Type – G** Page 18  
For limited end float

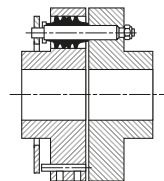

**Type – E** Page 18  
With adjustable end float



**Type – X** Page 19  
Special designs

### 2 Coupling Material

- G** Cast iron\*)
- K** Spheroidal cast iron\*)
- S** Steel
- X** Special materials

### 3 Intermediate Ring

- O** Without intermediate ring
- Z** With intermediate ring

### 4 Bolt Design

- M** Solid
- H** Hollow
- X** Special designs

### 5 Type of Compression Sleeve

- U** Modified rubber
- V** Chloroprene-polymeride
- W** Nitrile rubber

### 6 Coupling Size

ELCO-Coupling of standard design (**N**) made of steel (**S**), without (**O**) intermediate ring, with solid (**M**) bolts and (**U**) type compression sleeves. Coupling size 247.

	<b>1</b>	<b>2</b>	<b>3</b>	<b>4</b>	<b>5</b>	<b>6</b>
<b>ELCO-Coupling</b>	<b>N</b>	<b>S</b>	<b>O</b>	<b>M</b>	<b>U</b>	<b>- 247</b>

For information and technical data for ELCO-Coupling series A (can be disengaged at standstill) please see the separate data sheet.

\*) Upon special request; limited availability

Contents	Page
Technical Information	4
Sizing	6
Selection Factors	7
Permissible Misalignment	8
Reset Forces from Radial Displacement	9
Dimension Chart	
Type N/W	10
Type B	14
Type S	16
Type G/E	18
Special Designs	19
Weights	20
Moments of Inertia	21
Spare Parts	22

*The weights given in the tables are average values and not binding. The same is valid for the illustrations.*

*Alterations may be made in the interests of technical progress. This technical document is protected by law (DIN ISO 16016).*

*Couplings used in transport and industrial service must be provided with circumferential reinforcement, covers or guards to comply with the accident prevention regulations. (VGB 6 § 1, Abs. 3, VGB 7 a § 3, Abs. 4).*

### **ELCO Torsionally Flexible Coupling**

effectively absorbs shocks and suppresses vibrations which arise during operation. Moreover, it takes up radial and angular misalignments of the connected shafts and allows a certain amount of longitudinal displacements.

Assembly of a correctly designed **ELCO-Coupling** ensures safe power transmission and provides general protection of the respective machine shafts against vibration damage.

The **ELCO-Coupling** has proved itself in tens of thousands of drives through its adaptable design and its accurate workmanship.

The **ELCO-Coupling** shows the following advantages:

- Torque and speed shock loads are diminished by the resilience and damping effect of the compression sleeves.
- Torsional vibrations are effectively limited by a shifting of the natural frequencies of the system in areas which are not critical for the operating range.
- Torsional vibrations are effectively limited by the damping effect of the coupling when passing through the critical speed.
- Safe and reliable torque transfer results from the coupling bolt design and from the axial pre-loading of the compression sleeves.
- Radial and angular misalignments are compensated by the universal flexibility of the compression sleeves and by the ease with which they are deformed.
- Longitudinal displacements of the shafts are taken up by the ability of the compression sleeves to move slightly in the mating holes.
- Axial dismantling of the compression sleeves and coupling bolts is troublefree without any need for removing the coupling or for moving the connected units (for changing the sleeves or for test runs etc.)
- Machines can be aligned when the coupling bolts are not in position.

# Technical Information

## Flexible Compression Sleeve Coupling

All rigid components of the **RENK ELCO Couplings** are made of steel as a standard. For other materials including cast iron please contact your local RENK representative or RENK Hannover plant directly.

The bores for the coupling bolts and sleeves are accurately spaced and machined to a fine finish. The arrangement of all bolts in one coupling half offers the advantage of accommodating shaft ends of large-diameter.

**ELCO-Couplings** with pre-machined bores can be supplied only unbalanced.

The torque is transmitted by means of coupling bolts and compression sleeves of high grade elastomer (Fig. 1 and 2). All **ELCO-Couplings** types consist essentially of coupling flanges 1 and 2. The steel coupling bolts, on which the compression sleeves are mounted, are fitted in flange 2 and engage with the holes in flange 1. With Type W: the transmission elements are placed on both flanges of the coupling in alternate order.

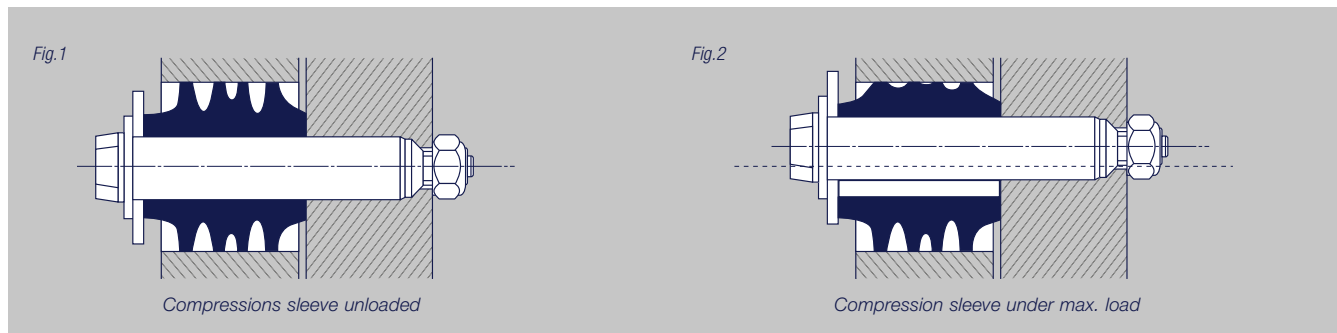

### Static balancing

**ELCO-Coupling** halves with finished bores correspond to balancing quality G16 for balancing in a plain surface (DIN 740, Part 1).

### Dynamic balancing

**ELCO-Coupling** size 018 to 454 with finished bore, extra price to be quoted. Dynamic balancing will be done upon request either before or after keywaying (G = Quality classes according to DIN ISO 1940, part 1). Following qualities are applied in case no "class (G) at speed" has been specified:

#### G 6,3

For all couplings running up to speed limit I. For speeds > 1500 rpm the value for n = 1500 rpm applies constantly.

#### G 2,5

For all couplings running within speed limits I to II. For speeds > 1500 rpm the value for n = 1500 rpm applies constantly.

**ELCO-Coupling** sizes 018 to 129 are fitted with non removable coupling bolts and can be drawn apart, therefore, only in an axial direction. On the other hand, couplings from size 149 on are provided with detachable transmission bolts which makes radial dismantling possible.

The compression sleeves are made of high quality, reinforced elastomer, which ensures the extraordinary performance range of the **ELCO Couplings** compared to most other couplings. Placement on a bolt circle with a diameter as small as possible provides a great twisting angle. Several differently deep groove profiles at periphery of the sleeves provide progressive torsion spring characteristics. Due to the elasticity of the profile sleeves, only minor restoring forces occur on the bearings.



Since the amplitude of the restoring forces depends on different variables, please ask for more details.

The compression sleeve is fixed to the bolt by a disc and a locking ring. By tightening the locknut, the bolt is pulled to its end position, thus avoiding the slackening of the fit of the compression sleeve.

**The following profile sleeves are available:**

**1. Compression sleeves U**

Compression sleeves of modified natural rubber with vulcanised polyamide inner sleeves are used for all standard drives. They have also proved to be an excellent solution for asymmetrically working drives with alternating torques, in particular for vibration-prone machines, i. e. Diesel engines and other piston engines.

**2. Compression sleeves V**

Compression sleeves of chloroprene polymer with vulcanised polyamide inner sleeves are especially designed for couplings exposed to oil vapours (mineral oils). They can also be used for machines in tropical areas with exposure to termites.

**3. Compression sleeves W**

Compression sleeves of nitric rubber with polyamide inner sleeve are used for drives requiring twisting angles smaller than those being achieved with type U sleeve. Sleeves type W are oil-resistant to a certain extent.

All **ELCO-Coupling** designs can be equipped with any of the compression sleeve type listed above (twisting angle chart on page 6).

The compression sleeves must be protected against UV radiation and heat, as otherwise changes in the vibration behaviour may occur (DIN 7716). These factors accelerate the aging process by modifying the spring characteristics and the damping properties of the sleeves.

Typical applications			
Coupling size	Speed [rpm]	Power [kW]	Application
335	985	1900	Cement mill
420	62	560	Conveyor belt
184	970	30	Belt drive
149	2000	15	Compressor
420	590	6300	Exhauster
271	1475	730	Centrifugal pump
454	585	7100	Generator
149	5000	17	D.C. Machine
247	1480	132	Converter
335	1800	2500	Turbo-generator on ships
231	3600	410	Reversing gear on ships

**General Description of the ELCO-Coupling**

As per the standard definition according to DIN 740, flexible and damping couplings are described as torsionally flexible shaft couplings.

Rotation flexible couplings are designed to influence the rotational vibration behaviour of drive systems in a targeted way. Using them may drastically decrease the strain amplitudes and the frequency of overload peaks during irregular operating phases in the torque-transmitting parts of drive units. As to machines with unequal torques in stationary cases (i.e. piston machines) quieter running is achieved by shifting the critical torque areas. Finally, due to their overall elasticity characteristics, the radial, axial and angular shaft displacements can be compensated, thus obviating the need for the commonly expensive machine foundations.

The **ELCO-Coupling** series covering an extremely large nominal torque from 18 Nm to 540 000 Nm are best suitable for application in many areas of power transmission as an all-round flexible coupling whose flexible elements can be easily changed.



# Sizing

## and Selection Criteria

The selection factor  $K$  is the main parameter in determining the right size of an **ELCO-Coupling**.

According to DIN 740, using  $T_{AN}$  and  $K$  the required coupling torque  $T_{KN}$  can be calculated.

Specific values for computerised simulation of unsteady torsional loads are available upon request.

$$T_{AN} = \frac{9550 \cdot P_M}{n}$$

$$K = S_B \cdot S_T \cdot S_S \cdot S_A$$

$$T_{KN} = T_{AN} \cdot K$$

$T_{AN}$  = Drive torque [Nm]  
 $T_{KN}$  = Rated torque of coupling [Nm]  
 $K$  = Selection factor  
 $S_B$  = Load factor  
 $S_T$  = Temperature factor  
 $S_S$  = Switch on factor  
 $S_A$  = Engine factor  
 $P_M$  = Motor power <sup>2)</sup> [kW]  
 $n$  = Shaft speed [rpm]

Coupling size	Max. speeds <sup>1)</sup>		Coupling-torque $T_{KN}$ [Nm]	Torsion angle $\varphi$ [°] static, at $T_{KN}$		
	I [rpm]	II [rpm]		Sleeve U	Sleeve V	Sleeve W
018 036	6000	—	$18 \cdot 10^0$ $36 \cdot 10^0$	3,4	2,9	2,2
044 066	6000	—	$44 \cdot 10^0$ $66 \cdot 10^0$	3,0	2,5	1,9
098 113	6000	—	$98 \cdot 10^0$ $13 \cdot 10^1$	2,9	2,4	1,9
123 129	6000	—	$23 \cdot 10^1$ $29 \cdot 10^1$	3,1	2,0	2,0
149 161	3600	5600	$49 \cdot 10^1$ $61 \cdot 10^1$	3,3	2,2	2,2
184 210	3000	5000	$84 \cdot 10^1$ $10 \cdot 10^2$	2,9	1,9	1,9
214 215	2650	4500	$14 \cdot 10^2$ $15 \cdot 10^2$	2,9	1,9	1,9
222 228	2250	4000	$22 \cdot 10^2$ $28 \cdot 10^2$	3,0	2,1	2,1
231 237	2000	3600	$31 \cdot 10^2$ $37 \cdot 10^2$	2,6	1,8	1,8
247 259 W	1800	3300	$47 \cdot 10^2$ $59 \cdot 10^2$	3,2	2,3	2,3
271 285 W	1650	3000	$71 \cdot 10^2$ $85 \cdot 10^2$	2,8	2,0	2,0
311 314 W	1500	2800	$11 \cdot 10^3$ $14 \cdot 10^3$	3,3	2,3	2,3
316 319 W	1250	2500	$16 \cdot 10^3$ $19 \cdot 10^3$	2,8	2,0	2,0
324 329 W	1120	2250	$24 \cdot 10^3$ $29 \cdot 10^3$	3,0	2,1	2,1
335 341 W	1000	2000	$35 \cdot 10^3$ $41 \cdot 10^3$	2,5	1,8	1,8
353	850	1750	$53 \cdot 10^3$	2,7	2,0	2,0
378	750	1500	$78 \cdot 10^3$	2,1	1,5	1,5
412	630	1300	$12 \cdot 10^4$	2,6	1,8	1,8
416	630	1300	$16 \cdot 10^4$	2,4	1,7	1,7
420	560	1200	$20 \cdot 10^4$	2,0	1,5	1,5
426	500	1050	$26 \cdot 10^4$	2,7	1,9	1,9
432	500	1050	$32 \cdot 10^4$	2,5	1,8	1,8
443	450	890	$43 \cdot 10^4$	2,2	1,5	1,5
454	400	750	$54 \cdot 10^4$	1,6	1,2	1,2

1) For maximum speed II, from size 149 on, only steel couplings with hollow bolts are admissible. 2) Selection according to motor power.

# Selection Factors

## for ELCO-Couplings

Driven machine	Load factor $S_g$ Type of sleeve	
	U	V, W
Generators with constant power output, light lineshafts, small fans, rotary machine tools, small centrifugal pumps, flour milling machines, light textile machines, light lifts, elevators and other conveyors.	1,3	1,5–1,6
Auxiliary machines for ships, shears, cranes, grinding machines, heavy lifts, generators with slightly variable output, coilers, chain conveyors, sand blast units, textile machines, line shafting, medium fans/blowers, large rotary machine tools, winches, centrifugal pumps, rotary pumps and compressors, smoothly running stirrers, reversible machine tools, belt conveyors, wood working machinery, ring frames, washing machines, looms.	1,4–1,5	1,6–1,7
Passenger lifts, rotary kilns, tanning barrels, paper machines large fans, cooling drums, stirrers, roller frames, looms, brick presses, printing machines, crushing plants, sugar mill machinery, wood grinders, mine fans, ship's propellers, draw benches.	1,6–1,7	1,8–1,9
Dredger drives, briquette presses, rubber rolling mills, coal pulverizers, piston pumps with fly wheel, reciprocating presses with light fly wheel, pug mills for sand and paper, plunger pumps, tumblers, vibrators, combination mills, cement mills, forging machines, piston and stamping presses, small ferrous rolling mills, roller tables for rolling mills.	1,8–1,9	2,1–2,3
Couching machines, horizontal saw frames, wet presses, paper calender, rolling devices for paper, drying cylinders, heavy centrifuges, crushing machines.	2,0–2,1	2,6–2,8

Load factors for cold and hot rolling mills with or without flywheels, road construction machines, welding and frequency converters with shock loads and other special machines upon request.

For drive systems with heavy shock loads we recommend a computerised simulation of unsteady torsional loads.

Inside of the machine groups (load factor) the lower values are for light-weight types and the higher values for heavy-weight types. In case of using combustion engines we recommend a computerised simulation of unsteady torsional loads.

Temperature factor $S_T$			
Compression sleeve	U	V	W
-20 – +30 °C	1,0	1,0	1,0
> +30 – +40 °C	1,1	1,2	1,0
> +40 – +60 °C	1,2	1,4	1,1
> +60 – +70 °C	1,3	1,5	1,2
> +70 – +80 °C	-	1,7	1,4

Switch on factor $S_s$	
s/h	
< 40	1,0
< 80	1,1
< 120	1,2
< 120–360	1,3

Engine factor $S_A$			
E-motors, turbine	Combustion engine, Diesel/Otto engine		
	> 6 Cylinder	≥ 3 Cylinder	≥ 1 Cylinder
1,0	1,1	1,4	1,6

# Permissible Misalignment

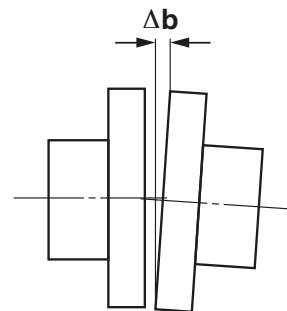
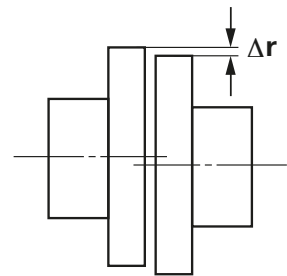
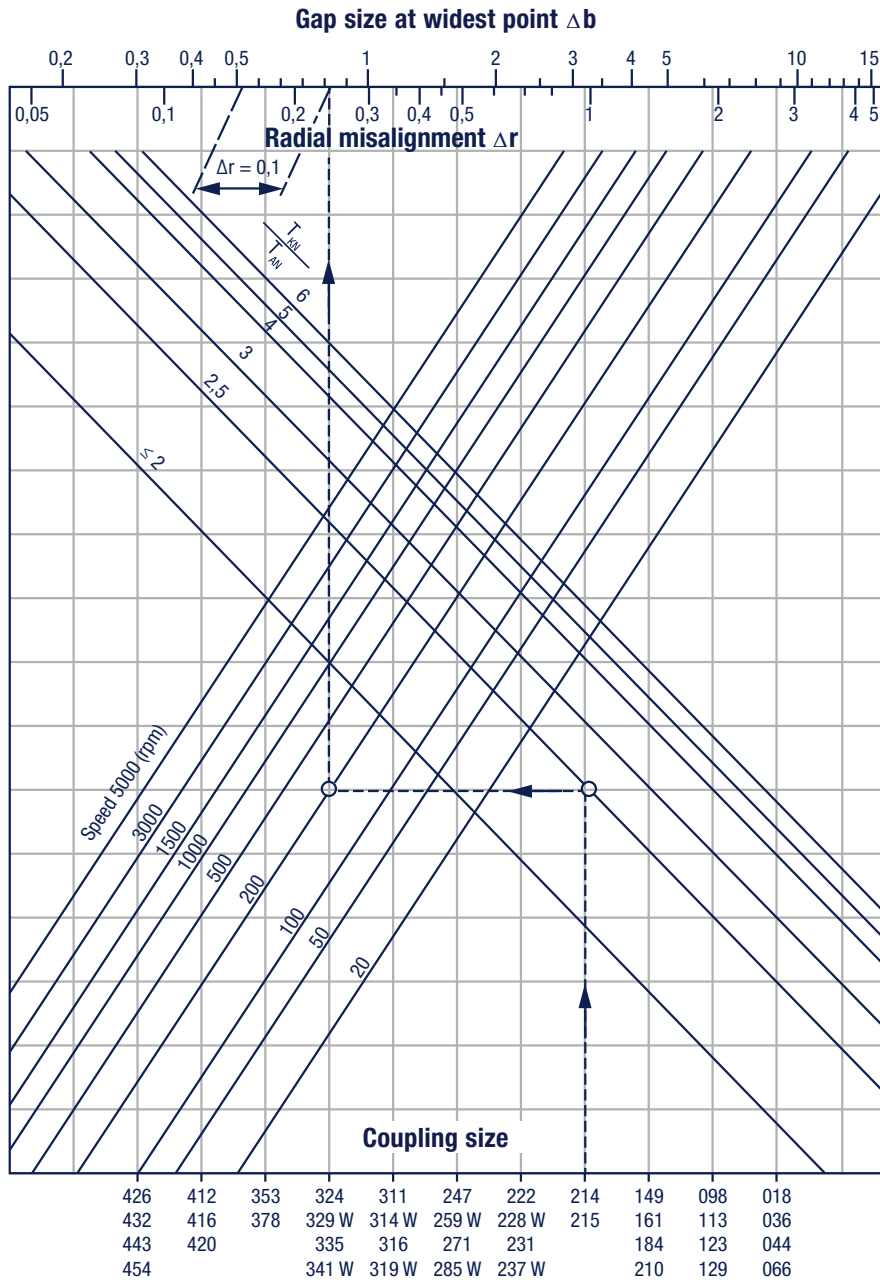

The permissible angular misalignment  $\Delta\alpha$  is given as a measurable linear dimension  $\Delta b$ .

**Example:**

ELCO-Coupling size 214 with  $T_{KN}/T_{AN} = 2,5$  and speed  $n = 200$  rpm

1. Permissible radial misalignment:  $\Delta r = 0,25$  mm or
2. Permissible angular misalignment:  $\Delta\alpha$  corresponding  $\Delta b = 0,85$  mm or
3. Permissible radial and angular misalignment: in case there is already  $\Delta b = 0,5$  then  $\Delta r$  can be  $0,25$  minus  $0,15 = 0,1$  mm.





# Readjustment Forces

## from Radial Displacement

Misalignment of the coupled shafts leads to dynamic deformations of the compression sleeves, which have the rotational frequency of the drive train. These deformation forces mix with the forces resulting from the torque transmission.

Reaction forces due to a radial offset counteract the direction of displacement and have an impact on the loading of the adjacent bearings.

The value of the static reaction force  $F_r$  can be calculated according to the formula below. Beside the characteristic material behaviour of the compression sleeves it is also the parameter  $T_{AN}/T_{KN}$  which influences the value of the reaction force  $F_r$ .

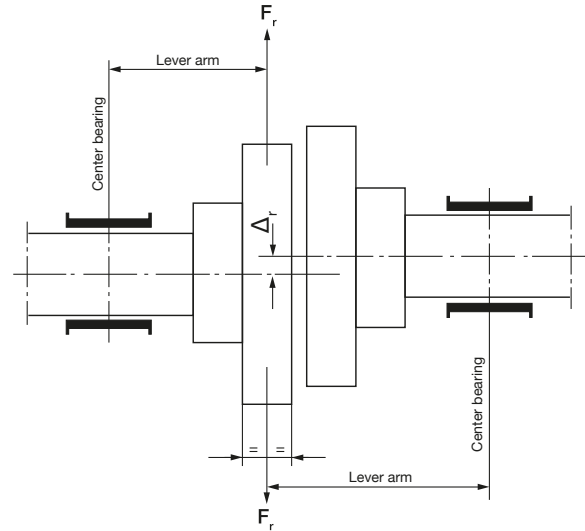

Valid for compression sleeves type U <sup>1)</sup>			
Size	DL	$C_{Tu\ stat}$	$C_{To\ stat}$
018	58	$2,2 \cdot 10^2$	$4,3 \cdot 10^2$
036		$4,4 \cdot 10^2$	$8,7 \cdot 10^2$
044	68	$6,0 \cdot 10^2$	$1,2 \cdot 10^3$
036		$9,0 \cdot 10^2$	$1,8 \cdot 10^3$
098	78	$1,4 \cdot 10^3$	$2,7 \cdot 10^3$
113		$1,9 \cdot 10^3$	$3,6 \cdot 10^3$
123	95	$2,8 \cdot 10^3$	$7,1 \cdot 10^3$
129		$3,5 \cdot 10^3$	$9,0 \cdot 10^3$
149	116	$5,3 \cdot 10^3$	$1,5 \cdot 10^4$
161		$6,7 \cdot 10^3$	$1,8 \cdot 10^4$
184	145	$1,0 \cdot 10^4$	$3,1 \cdot 10^4$
210		$1,2 \cdot 10^4$	$3,7 \cdot 10^4$
214	170	$1,7 \cdot 10^4$	$5,0 \cdot 10^4$
215		$1,9 \cdot 10^4$	$5,4 \cdot 10^4$
222	205	$2,5 \cdot 10^4$	$7,9 \cdot 10^4$
228		$3,1 \cdot 10^4$	$1,0 \cdot 10^5$
231	235	$4,1 \cdot 10^4$	$1,3 \cdot 10^5$
237		$4,9 \cdot 10^4$	$1,5 \cdot 10^5$
247	255	$4,7 \cdot 10^4$	$1,8 \cdot 10^5$
259 W		$5,9 \cdot 10^4$	$2,2 \cdot 10^5$

Valid for compression sleeves type U <sup>1)</sup>			
Size	DL	$C_{Tu\ stat}$	$C_{To\ stat}$
271	295	$7,8 \cdot 10^4$	$3,1 \cdot 10^5$
285 W		$9,4 \cdot 10^4$	$3,8 \cdot 10^5$
311	335	$1,0 \cdot 10^5$	$4,4 \cdot 10^5$
314 W		$1,3 \cdot 10^5$	$5,7 \cdot 10^5$
316	390	$1,7 \cdot 10^5$	$7,5 \cdot 10^5$
319 W		$2,1 \cdot 10^5$	$8,8 \cdot 10^5$
324	425	$2,5 \cdot 10^5$	$9,8 \cdot 10^5$
329 W		$3,0 \cdot 10^5$	$1,2 \cdot 10^6$
335	505	$4,3 \cdot 10^5$	$1,7 \cdot 10^6$
341 W		$5,0 \cdot 10^5$	$2,0 \cdot 10^6$
353	585	$5,9 \cdot 10^5$	$2,5 \cdot 10^6$
378		$1,2 \cdot 10^6$	$4,2 \cdot 10^6$
412	750	$1,5 \cdot 10^6$	$5,6 \cdot 10^6$
416		$2,1 \cdot 10^6$	$8,3 \cdot 10^6$
420	950	$3,1 \cdot 10^6$	$1,2 \cdot 10^7$
426		$2,9 \cdot 10^6$	$1,3 \cdot 10^7$
432	1025	$4,0 \cdot 10^6$	$1,6 \cdot 10^7$
443		$5,9 \cdot 10^6$	$2,6 \cdot 10^7$
454	1320	$8,5 \cdot 10^6$	$3,6 \cdot 10^7$

### Values and units:

$C_{Tstat}$  [Nm/rad] effective static coupling torsional stiffness

$C_{Tostat}$  [Nm/rad] static torsional stiffness under  $T_{KN}$

$C_{Tustat}$  [Nm/rad] static torsional stiffness at zero displacement

$D_L$  [mm] pitch circle

$\Delta_r$  [mm] radial displacement

$F_r$  [N] radial force

$T_{AN}$  [Nm] drive torque

$T_{KN}$  [Nm] nominal coupling torque

$$F_r = \frac{C_{Tstat} \cdot 10^3}{[0,5 D_L]^2} \cdot \Delta_r \quad [N]$$

$$C_{Tstat} = C_{Tustat} \left[ \frac{C_{Tostat}}{C_{Tustat}} \right] \frac{T_{AN}}{T_{KN}} \quad [Nm/rad]$$

The values for  $D_L$ ,  $C_{Tustat}$  and  $C_{Tostat}$  can be taken from the chart.

<sup>1)</sup> Valid for compression sleeves type V and W upon request.

### Example:

Input: ELCO-Coupling size 324 with compression sleeves type U,  $T_{KN} = 24000$  Nm, drive torque  $T_{AN} = 7000$  Nm, radial displacement = 0,8 mm.

### Output: Magnitude of radial force $F_r$

The static torsional stiffness is:

$$C_{Tstat} = 2,5 \cdot 10^5 \left[ \frac{9,8 \cdot 10^5}{2,5 \cdot 10^5} \right] \frac{7000}{24000} = 3,72 \cdot 10^5 \quad [Nm/rad]$$

Result:

$$F_r = \frac{3,72 \cdot 10^5 \cdot 10^3}{212,5^2} \cdot 0,8 = 6590 \quad [N]$$

# Type N / W

## Sizes 018 – 319 W



The **ELCO-Coupling** type N and W are used for the flexible connection of shafts.

### Description:

The **ELCO-Coupling** type N consists essentially of the two coupling halves, flanges 1 and 2 and the transmission bolts (4), on which the rubber compression sleeves (5) are mounted.

The finely ground transmission bolts (4) are made of steel and are inserted with a specially close fit in the bores (3) of the half coupling, flange 2. They engage, with their axially pre-loaded compression sleeves, in the bores provided in the coupling half, flange 1.

The **ELCO-Coupling** type W is a complementary version of the well-known type N. **ELCO-Coupling** type W consists of two identical coupling parts, each with transmitting bolts and compression sleeves arranged in alternate order.

Coupling size	Coupling torque $T_{KN}$ [Nm]	Max. speeds <sup>1)</sup>		Steel Flange 1 and 2													
		$l$ [rpm]	$ll$ [rpm]	$a_1$ [mm]	$l_1$ $l_2$ [mm]	$b_{max}^{2)}$ [mm]	$z$ [mm]	$h_1$ $h_2$ [mm]	$o$ [mm]	$p$ [mm]	$D_1^{6)}$ [mm]	$d^{6)}$	$t^{6)}$ [mm]	$x^{3)}$ [mm]	$x^{*3)}$ [mm]	$y^{4)}$ [mm]	
018 036	$18 \cdot 10^0$ $36 \cdot 10^0$	6000	—	87	30	6	—	21	30	—	40	M 6	12	28	—	28	
044 066	$44 \cdot 10^0$ $66 \cdot 10^0$	6000	—	97	35	6	—	21	30	—	50	M 8	15	25	—	25	
098 113	$98 \cdot 10^0$ $13 \cdot 10^1$	6000	—	112	40	6	—	26	36	—	60	M 8	15	30	—	30	
123 129	$23 \cdot 10^1$ $29 \cdot 10^1$	6000	—	130	50	6	—	26	36	—	70	M 8	15	20	—	20	
149 161	$49 \cdot 10^1$ $61 \cdot 10^1$	3600	5600	160	60	4	16	30	46	42	80	M 10	20	25	40	25	
184 210	$84 \cdot 10^1$ $10 \cdot 10^2$	3000	5000	190	75	4	16	30	46	42	100	M 10	20	10	25	10	
214 215	$14 \cdot 10^2$ $15 \cdot 10^2$	2650	4500	225	90	5	20	37	54	49	115	M 12	25	10	25	15	
222 228	$22 \cdot 10^2$ $28 \cdot 10^2$	2250	4000	270	100	6	20	45	63	61	125	M 12	25	20	35	20	
231 237	$31 \cdot 10^2$ $37 \cdot 10^2$	2000	3600	300	120	6	20	45	63	61	145	M 12	25	5	15	0	
247 259 W	$47 \cdot 10^2$ $59 \cdot 10^2$	1800	3300	340	140	6	25	55	74	73	170	M 16	30	5	20	0	
271 285 W	$71 \cdot 10^2$ $85 \cdot 10^2$	1650	3000	380	160	6	25	55	74	73	185	M 20	35	0	0	0	
311 314 W	$11 \cdot 10^3$ $14 \cdot 10^3$	1500	2800	440	180	7	25	68	90	92	205	M 20	35	0	10	0	
316 319 W	$16 \cdot 10^3$ $19 \cdot 10^3$	1250	2500	500	200	7	25	68	90	92	225	M 20	35	0	0	0	

1) For maximum speed  $ll$ , from size 149 on only steel couplings with hollow bolts must be used.

2) Standard fitting dimension  $b_{nom} = 1/2 b_{max}$

3) Space required for driving out the transmission bolts:  $x$  = for couplings without intermediate ring,  $x^*$  = for couplings with intermediate ring.

4)  $y$  = space required for removing the compression sleeves.

5) The intermediate ring is made of steel.

6) With adjusting screw up to size 237 on request - from size 247 on adjusting screw are provided as standard.

## Type N

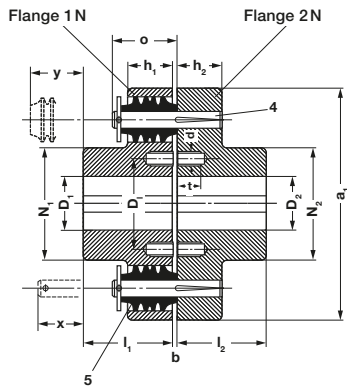

Design for sizes 018 – 129

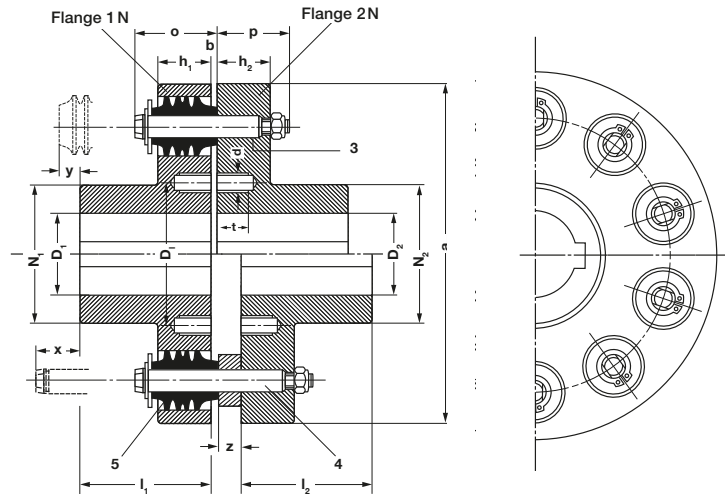

Design with intermediate ring for sizes 149 – 316

## Type W

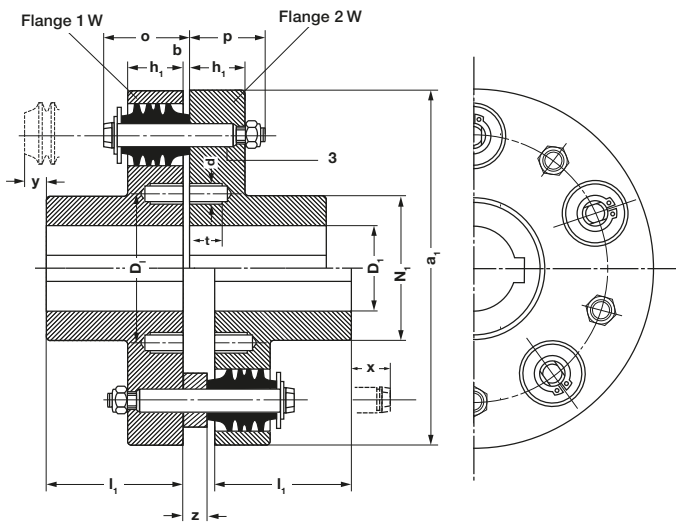

Design with intermediate ring

Coupling size	Steel					
	Flange 1 N / 1 W / 2 W			Flange 2 N		
	Hub N <sub>1</sub> [mm]	Pilot hole <sup>2)</sup> [mm]	Finished bore <sup>1)</sup> D <sub>1</sub> [mm]	Hub N <sub>2</sub> [mm]	Pilot hole <sup>2)</sup> [mm]	Finished bore <sup>1)</sup> D <sub>2</sub> [mm]
018						
036	35	9	10–20	40	9	10–25
044						
066	45	11	12–28	50	11	12–30
098						
113	52	15	16–32	63	15	16–40
123						
129	68	18	19–45	80	18	19–52
149						
161	82	18	19–55	82	18	19–55
184						
210	110	23	24–75	110	23	24–75
214						
215	125	29	30–85	135	29	30–90
222						
228	150	34	35–100	150	34	35–100
231						
237	180	39	40–120	180	39	40–120
247						
259 W	180	44	45–120	200	44	45–135
271						
285 W	220	53	55–145	220	53	55–145
311						
314 W	250	63	65–165	250	63	65–165
316						
319 W	280	73	75–185	280	73	75–185

### Information for engineers

The ELCO-Coupling can be extended in axial direction. As of size 149, radial dismantling of the coupled shafts is possible without axial shifting after dismantling the bolts.

For greater shaft distances, the ELCO-Coupling can be equipped with intermediate rings. For max. admissible shaft distances please see the chart on page 10.

Speed	Material	Intermediate ring <sup>3)</sup>	Bolts
I	steel	without / with	solid
II	steel	with	hollow

Bore of hub chamfered: sizes 018 - 129 = 1 x 45°, sizes 149 - 259 W = 1,5 x 45°, sizes 271 - 319 W = 2 x 45°

1) The couplings are normally bored to DIN ISO 286-2 using ISO tolerances "K 7" or "H 7".  
Recommended fit is: h 6 / K 7 or m 6 / H 7 or k 6 / H 7.  
Sizes 018–210 will always be supplied with adjusting screw when ready bored and keywayed.

2) Pilot holes have no fit tolerance. Parallel keys and taper keys are supplied on request, at extra charge.

With high shock-loads or reduced hubs respectively, the load on the key must be checked.

3) Sizes and dimensions of ELCO-Couplings made of cast iron upon request.

# Type N / W

## Sizes 324 – 454

The **ELCO-Coupling** types N and W are used for the flexible connection of shafts.

### Description:

The **ELCO-Coupling** type N consists essentially of the two coupling halves, flanges 1 and 2 and the transmission bolts (4), on which the rubber compression sleeves (5) are mounted.

The finely ground transmission bolts (4) are made of steel and are inserted with a specially close fit in the bores (3) of

the half coupling, flange 2. They engage, with their axially pre-loaded compression sleeves, in the bores provided in the coupling half, flange 1.

The **ELCO-Coupling** type W is a complementary version of the well-known type N.

**ELCO-Coupling** type W consists of two identical coupling parts, each with transmitting bolts and compression sleeves arranged in alternate order.

Coupling size	Coupling torque $T_{KN}$ [Nm]	Max. speeds <sup>1)</sup>		Steel Flange 1 and 2													
		l [rpm]	ll [rpm]	$a_1$ [mm]	$l_1$ $l_2$ [mm]	$b_{max}^{2)}$ [mm]	z [mm]	$h_1$ [mm]	$h_2$ [mm]	f [mm]	o [mm]	p [mm]	$D_1$ [mm]	d	t [mm]	x, x* <sup>3)</sup> [mm]	y <sup>4)</sup> [mm]
324 329 W <sup>3)</sup>	$24 \cdot 10^3$ $29 \cdot 10^3$	1120	2250	560	220	8	30	83	76 —	46	106	107	240/280 240	M 20	35	0	0
335 341 W <sup>3)</sup>	$35 \cdot 10^3$ $41 \cdot 10^3$	1000	2000	640	250	8	30	83	76 —	46	106	107	280 260	M 20	35	0	0
353	$53 \cdot 10^3$	850	1750	750	280	9	30	102	93	58	127	128	300	M 24	42	0	0
378	$78 \cdot 10^3$	750	1500	880	320	9	—	102	93	58	127	128	210 250 290 330	M 24	42	0	0
412	$12 \cdot 10^4$	630	1300	960	350	10	—	128	115	60	158	159	240 280 320 380	M 30	55	0	0
416	$16 \cdot 10^4$	630	1300	1040	375	10	—	128	115	60	158	159	240 280 320 380	M 30	55	0	0
420	$20 \cdot 10^4$	560	1200	1160	400	10	—	128	115	60	158	159	260 310 360 420	M 36	65	0	0
426	$26 \cdot 10^4$	500	1050	1210	425	12	—	160	148	75	195	200	310 360 410 440 480	M 36	65	0	0
432	$32 \cdot 10^4$	500	1050	1285	450	12	—	160	148	75	195	200	320 400 470 510 570	M 42	75	0	0
443	$43 \cdot 10^4$	450	890	1430	500	12	—	160	148	75	195	200	330 410 490 530 590	M 42	70	0	0
454	$54 \cdot 10^4$	400	750	1580	560	12	—	160	148	75	195	200	370 440 510 580 650	M 48	80	0	0

<sup>3)</sup> ELCO-Couplings type W only available in steel.

Couplings for torque higher than  $T_{KN} = 54 \cdot 10^4$  Nm are available upon request.

Observe the footnotes on pages 10 and 11.

## Type N

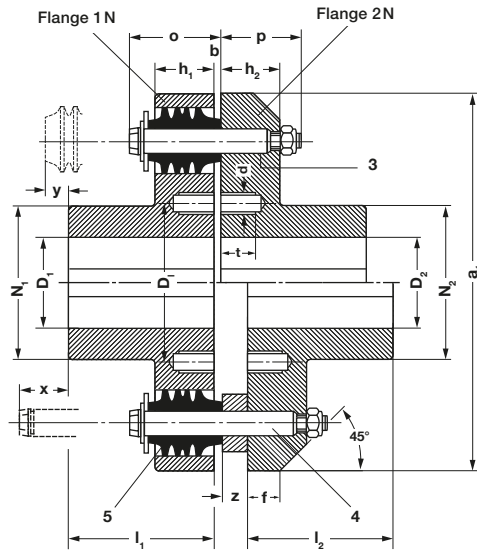

Design with intermediate ring for sizes 324–454

Bore of hub chamfered: sizes 324–353 = 2 x 45°, sizes 378–454 = 3 x 45°

Coupling size	Steel					
	Flange 1 N / 1 W / 2 W			Flange 2 N		
	Hub N <sub>1</sub> [mm]	Pilot hole <sup>2)</sup> [mm]	Finished bore <sup>1)</sup> D <sub>1</sub> [mm]	Hub N <sub>2</sub> [mm]	Pilot hole <sup>2)</sup> [mm]	Finished bore <sup>1)</sup> D <sub>2</sub> [mm]
324	290	on request	95–190	335	on request	95–220
329 W	275		85–180	—		—
335	335	on request	110–220	365	on request	110–240
341 W	305		95–200	—		—
353	365	on request	140–240	380	on request	140–250
378	245	on request	125–160	245	on request	125–160
	305		> 160–200	305		> 160–200
	365		> 200–240	365		> 200–240
	380		> 240–250	425		> 240–280
412	275	on request	140–180	275	on request	140–180
	335		> 180–220	335		> 180–220
	395		> 220–260	395		> 220–260
	425		> 260–280	485		> 260–320
416	275	on request	140–180	275	on request	140–180
	335		> 180–220	335		> 180–220
	395		> 220–260	395		> 220–260
	450		> 260–300	485		> 260–320
420	305	on request	160–200	305	on request	160–200
	380		> 200–250	380		> 200–250
	450		> 250–300	450		> 250–300
	485		> 300–320	545		> 300–360
426	350	on request	180–230	350	on request	180–230
	425		> 230–280	425		> 230–280
	500		> 280–330	500		> 280–330
	545		> 330–360	545		> 330–360
432	360	on request	190–240	360	on request	190–240
	450		> 240–300	450		> 240–300
	530		> 300–350	530		> 300–350
	570		> 350–380	570		> 350–380
443	380	on request	200–250	380	on request	200–250
	470		> 250–310	470		> 250–310
	560		> 310–370	560		> 310–370
	605		> 370–400	605		> 370–400
454	410	on request	220–270	410	on request	220–270
	500		> 270–330	500		> 270–330
	590		> 330–390	590		> 330–390
	680		> 390–450	680		> 390–450
	760		> 450–500	760		> 450–500

2) If not otherwise expressly specified, we supply coupling halves with a pilot hole 5 mm smaller in diameter than the desired finished bore size.

With enquiries or when ordering please state:

1. Type of coupling
2. Bore D in mm and tolerances for both flanges
3. Connection of shaft/hub
4. Kind of driving and driven machine
5. Maximum power to be transmitted, starting torque and magnitude of shock loads
6. Moments of inertia of driving and driven machine
7. Speed in rpm
8. Type of compression sleeves (U, V, W)
9. Ambient temperature
10. Frequency of engagements/disengagements

### Information for engineers

The ELCO-Coupling can be extended in axial direction. As of size 149, radial dismounting of the coupled shafts is possible without axial shifting after dismounting the bolts.

For greater shaft distances, the ELCO-Coupling can be equipped with intermediate ring spacers. For max. admissible shaft distances please see the chart on page 12.

Speed	Material	Intermediate ring <sup>5)</sup>	Bolts
I	steel	without / with	solid
II	steel	with	hollow



# Type B

## Shear Pin Coupling

The **ELCO-Coupling** type B is a modified version of the standard **ELCO-Coupling** in a safety coupling and serves as a protection of the torsion-flexibly connected machines against inadmissibly high overload. In case of overload, the two shafts are separated from each other by shearing off the shear pins.

Therefore, this coupling combines the characteristics of a torsion-flexible and an overload protection coupling.

**Description:**

The **ELCO-Coupling** type B consists of the coupling halves 1 and 2/12. Coupling half 1 corresponds to part 1 N of the standard **ELCO-Coupling**. As to part 2/12, hub part 12 is attached to the shaft. Part 2 is loosely placed on it. Both parts are connected by cast iron shear pins 14. The torque is transmitted via shear pin 14, transmission bolt 4 and com-

pression sleeves 5 that fit into the bore of coupling half 1. Shear pin and profile sleeves are connected in series. The loose rotary part 2 is held in place axially by disc 16. The running surface is lubricated via grease nipple 17. For certain applications with higher peripheral speed, the loosely rotary part 2 is positioned on part 12 via a PTFE-based sliding layer. The size of the maximum torque is determined by differently deep grooves of the shear pins. Due to differences in stability, the fracture torque  $T_{KB}$  has a scatter range of  $\pm 25\%$ . Therefore the fracture torque  $T_{KB}$  must have a sufficient safety distance from the drive moment  $T_{AN}$  ( $T_{KB} \approx 1,5 \times T_{AN}$ ).

After destruction of the shear pin due to excessive stress, the drive machine must be stopped immediately. The coupling is not designed for long run out periods.

Coupling size	Coupling torque $T_{KN}$ [Nm]	Min. permissible fracture torque $T_{KB}$ [Nm]	Max. speed $l$ [rpm]	Steel Flange 1 and 2/12																	
				$a_1$ [mm]	$l_1$ [mm]	$l_2^{(8)}$ [mm]	$b_{max}^{(3)}$ [mm]	$z$ [mm]	$h_1$ [mm]	$h_2$ [mm]	$f$ [mm]	$o$ [mm]	$p$ [mm]	$D_1^{(7)}$ [mm]	$d^{(7)}$ [mm]	$t^{(7)}$ [mm]	$x^{(4)}$ [mm]	$x^{*(4)}$ [mm]	$y^{(5)}$ [mm]	$m$ [mm]	$e$ [mm]
149	$49 \cdot 10^1$	160	3600	160	60	80	4	16	30	30	—	46	42	80	M 10	20	25	40	25	38	140
184	$84 \cdot 10^1$	280	3000	190	75	95	4	16	30	30	—	46	42	100	M 10	20	10	25	10	42	175
214	$14 \cdot 10^2$	340	2650	225	90	110	5	20	37	37	—	54	49	115	M 12	25	10	25	15	42	210
222	$22 \cdot 10^2$	650	2250	270	100	130	6	20	45	45	—	63	61	125	M 12	25	20	35	20	55	245
231	$31 \cdot 10^2$	740	2000	300	120	145	6	20	45	45	—	63	61	145	M 12	25	5	15	0	55	270
247	$47 \cdot 10^2$	1150	1800	340	140	160	6	25	55	55	—	74	73	170	M 16	30	5	20	0	68	310
271	$71 \cdot 10^2$	1250	1650	380	160	180	6	25	55	55	—	74	73	185	M 20	35	0	0	0	68	340
311	$11 \cdot 10^3$	2500	1500	440	180	200	7	25	68	68	—	90	92	205	M 20	35	0	10	0	85	390
316	$16 \cdot 10^3$	2800	1250	500	200	220	7	25	68	68	—	90	92	225	M 20	35	0	0	0	85	450
324	$24 \cdot 10^3$	6000	1120	560	220	240	8	30	83	76	46	106	107	240/280	M 20	35	0	0	0	110	510
335	$35 \cdot 10^3$	7000	1000	640	250	260	8	30	83	76	46	106	107	280	M 20	35	0	0	0	110	570
353	$53 \cdot 10^3$	10000	850	750	280	290	9	30	102	93	58	127	128	300	M 24	42	0	0	0	130	660

1) For manufacturing reasons, values below the minimum fracture torque are not permitted.  
 2) Higher torque on request.  
 3) Standard built in  $b_{norm} = 1/2 b_{max}$   
 4) Space required for driving out the transmission bolts:  $x$  = for couplings without intermediate ring,  $x^*$  = for couplings with intermediate ring.

5)  $y$  = space required for removing the compression sleeves.  
 6) The intermediate ring is made of steel.  
 7) With adjusting screw up to size 237 on request - from size 247 on adjusting screw are provided as standard.  
 8) At the same time the length of the shaft journal.

## Type B

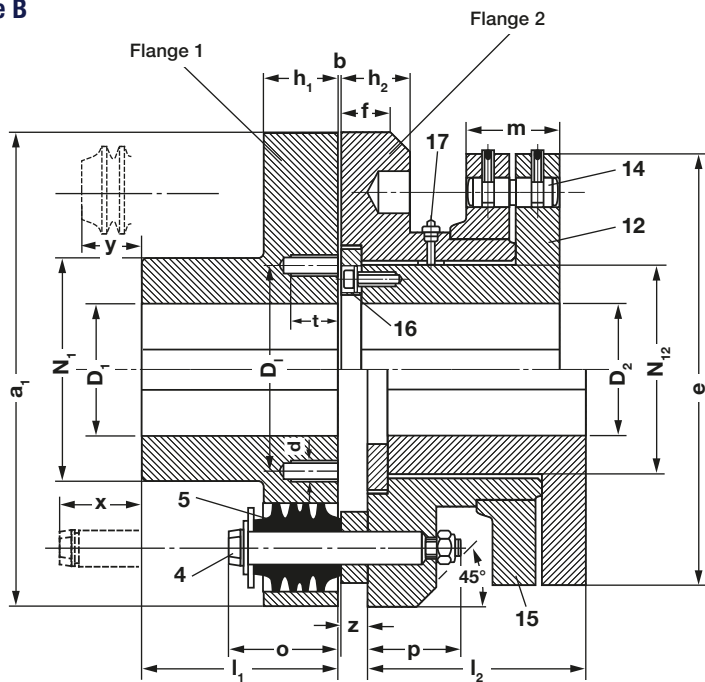

Design with intermediate ring

Bore of hub chamfered: sizes 149–247 = 1,5 x 45°, sizes 271–353 = 2 x 45°

### Information for engineers

The ELCO-Coupling can be extended in axial direction. As of size 149, radial dismounting of the coupled shafts is possible without axial shifting after dismounting the bolts.

For greater shaft distances, the ELCO-Coupling can be equipped with intermediate ring. For max. admissible shaft distances please see the chart on page 14.

Speed	Material	Intermediate ring <sup>5)</sup>	Bolts
I	steel	without / with	solid

### With enquiries or when ordering please state:

1. Type of coupling
2. Bore D in mm and tolerances for both flanges
3. Connection of shaft / hub
4. Kind of driving and driven machine
5. Maximum power to be transmitted, starting torque and magnitude of shock loads
6. Moments of inertia of driving and driven machine
7. Speed in rpm
8. Type of compression sleeves (U, V, W)
9. Ambient temperature
10. Frequency of engagements/ disengagements

Coupling size	Steel				
	Flange 1		Flange 2/12		
	Hub N <sub>1</sub> [mm]	Pilot hole <sup>2)</sup> [mm]	Finished bore <sup>1)</sup> D <sub>1</sub> [mm]	Hub N <sub>12</sub> [mm]	Finished bore <sup>1)</sup> D <sub>2</sub> [mm]
149	82	18	19–55	70	19–40
184	110	23	24–75	95	24–60
214	125	29	30–85	110	30–70
222	150	34	35–100	125	35–80
231	180	39	40–120	140	40–90
247	180	44	45–120	160	45–100
271	220	53	55–145	140 175	55–85 > 85–110
311	250	63	65–165	160 200	65–100 > 100–130
316	280	73	75–185	175 235	75–110 > 110–150
324	290	on request	95–190	235 280	85–140 > 140–170
335	335	on request	110–220	260 320	95–150 > 150–220
353	365	on request	140–240	290 360	110–170 > 170–220

1) The couplings are normally bored to DIN ISO 286-2 using ISO tolerances "K 7" or "H 7".

Recommended fit is: h 6 / K 7 or m 6 / H 7 or k 6 / H 7.

2) Pilot holes have no fit tolerances

3) If not otherwise expressly specified, we supply coupling halves with pilot

holes 5 mm smaller in diameter than the desired finished bore size.

Parallel keys and taper keys are supplied on request, at extra charge. With high shock loads or reduced hubs resp., the load on the key must be checked.

# Type S

## With Screwed-On Brake Drum to DIN 15431

The **ELCO-Couplings** type S are standard **ELCO-Couplings** combined with standard brake drums to DIN 15431.

### Description:

The **ELCO-Coupling** type S consists of the two coupling parts 1 and 2. Coupling part 1 complies with Part 1 N of standard type N. Part 2 is provided with an outside centering for fitting the brake drum 12. As of coupling size 149, the retaining screws 13 and the transmission bolts 4 mounted in part 2 serve also as attachments for the brake drum. The transmission bolts carry the compression sleeves 5 which engage into the provided bores of coupling half 1.



Coupling size	Coupling torque $T_{KN}$ [Nm]	Max. speed <sup>1)</sup>		Steel Flange 1 and 2												
		I [rpm]	II [rpm]	$a_1$ [mm]	$l_1$ $l_2$ [mm]	$b_{max}$ <sup>2)</sup> [mm]	$z$ [mm]	$h_1$ [mm]	$o$ [mm]	$D_f$ <sup>6)</sup> [mm]	$d$ <sup>6)</sup>	$t$ <sup>6)</sup> [mm]	$x$ <sup>3)</sup> [mm]	$x^*$ <sup>3)</sup> [mm]	$y$ <sup>4)</sup> [mm]	
123	$23 \cdot 10^1$	6000	—	130	50	6	—	26	36	70	M 8	15	20	20	20	
149	$49 \cdot 10^1$	3600	5600	160	60	4	16	30	46	80	M 10	20	25	40	25	
184	$84 \cdot 10^1$	3000	5000	190	75	4	16	30	46	100	M 10	20	10	25	10	
214	$14 \cdot 10^2$	2650	4500	225	90	5	20	37	54	115	M 12	25	10	25	15	
222	$22 \cdot 10^2$	2250	4000	270	100	6	20	45	63	125	M 12	25	20	35	20	
231	$31 \cdot 10^2$	2000	3150	300	120	6	20	45	63	145	M 12	25	5	15	0	
247	$47 \cdot 10^2$	1800	2500	340	140	6	25	55	74	170	M 16	30	5	20	0	
271	$71 \cdot 10^2$	1650	2000	380	160	6	25	55	74	185	M 20	35	0	0	0	
311	$11 \cdot 10^3$	1500	1600	440	180	7	25	68	90	205	M 20	35	0	10	0	
316	$16 \cdot 10^3$	1250	1400	500	200	7	25	68	90	225	M 20	35	0	0	0	
324	$24 \cdot 10^3$	1120	2250	560	220	8	30	83	106	240 280	M 20	35	0	0	0	

### Information for engineers

The ELCO-Coupling can be extended in axial direction. As of size 149, radial dismounting of the coupled shafts is possible without axial shifting after dismounting the bolts.

For greater shaft distances, the ELCO-Coupling can be equipped with intermediate ring. For max. admissible shaft distances please see the chart on page 16.

Speed	Material	Intermediate ring <sup>5)</sup>	Bolts
I	steel	without / with	solid
II	steel	with	hollow

- 1) For maximum speeds II, from size 149 on only steel couplings with hollow bolts must be used. Brake drums see page 17. If the permissible speed of the brake drum is less than the speed of the coupling, the brake drum speed is the one to be considered.
- 2) When assembling, standard dimension  $b_{norm} = 1/2 b_{max}$
- 3) Space required for driving out the transmission bolts  
 $x$  = for couplings without intermediate ring  
 $x^*$  = for couplings with intermediate ring.
- 4)  $y$  = space required for removing the compression sleeves.
- 5) The intermediate ring is made of steel.
- 6) With adjusting screw up to size 231 on request – from size 247 on adjusting screw are provided as standard. For diameters of bores and hubs see type N sizes 123 to 324.



## Type S

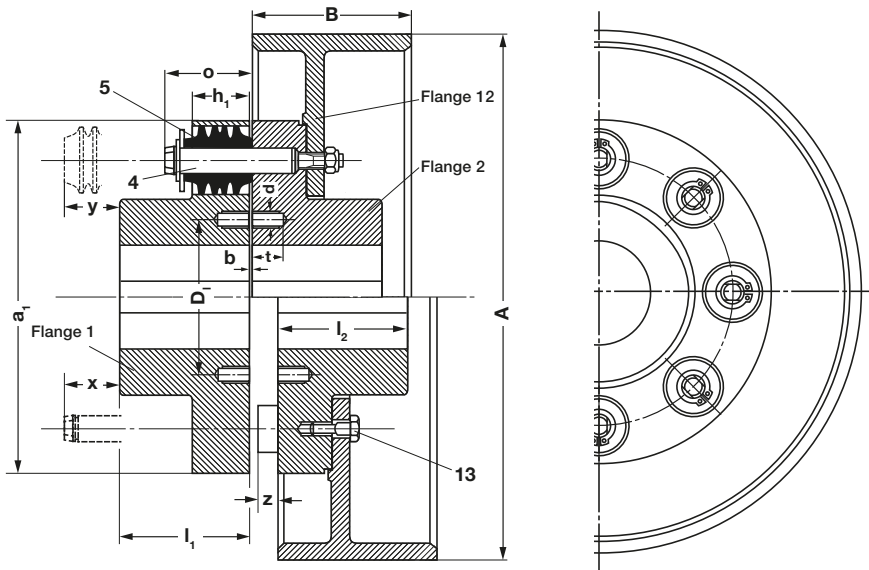

Design with intermediate ring

Bore of hub chamfered: sizes 123 = 1,5 x 45°, sizes 149–247 = 1,5 x 45°, sizes 271–324 = 2 x 45°

With enquiries or when ordering please state:

1. Type of coupling
2. Bore D in mm and tolerances for both flanges
3. Connection of shaft/hub
4. Kind of driving and driven machine
5. Maximum power to be transmitted, starting torque and magnitude of shock loads
6. Moments of inertia of driving and driven machine
7. Speed in rpm
8. Type of compression sleeves (U, V, W)
9. Ambient temperature
10. Frequency of engagements/disengagements

Available with brake discs DIN 15432 upon request.

Coupling size	Combination I			Combination II Brake drum to DIN 15431 (Flange 12) steel			Combination III		
	A [mm]	B [mm]	Permissible speed [rpm]	A [mm]	B [mm]	Permissible speed [rpm]	A [mm]	B [mm]	Permissible speed [rpm]
123	—	—	—	—	—	—	200	75	6000
149	—	—	—	200	75	5600	250	95	5000
184	—	—	—	250	95	5000	315	118	4000
214	250	95	4500	315	118	4000	400	150	3150
222	315	118	4000	400	150	3150	500	190	2500
231	400	150	3150	500	190	2500	630	236	2000
247	500	190	2500	630	236	2000	710	265	1600
271	630	236	2000	710	265	1600	800	300	1400
311	710	265	1600	800	300	1400	—	—	—
316	800	300	1400	—	—	—	—	—	—
324	800	300	1400	—	—	—	—	—	—

### Important notice for engineering and project management:

The coupling part with the brake drum should always be placed on the end of the shaft which has the bigger mass moment of inertia.

Parallel keys and taper keys are available upon request, at extra charge.

In case of high shock loads or shortened hubs, the parallel key load must be checked.

In addition to the brake drums listed up in the chart above, we also deliver brake drums in other dimensions upon request. The brake surface of the drums can be made of chrome and if requested, the **ELCO-Coupling** half 2 with brake drum can be made in one piece.

Further information upon request.

# Type G/E

## with Definite End Float

The **ELCO-Coupling** type G, size 149–319 W, is provided with devices which allows the longitudinal spacing between the coupled shaft ends to be fixed within certain pre-determined limits. With the **ELCO-Coupling** type E up to size 214 (with the exception of sizes 215, 228 and 237) it is also possible to vary the clearance and the distance between the coupling halves.

With these types a relatively small angular displacement is possible.

### Type G

Coupling halves 1 and 2 are both provided with an annular groove in which a divided ring 3 made of an extremely solid and corrosion-resistant light metal alloy fits in. The desired axial clearance as well as the provided gap "b" between coupling halves 1 and 2 must already be specified when placing the order.

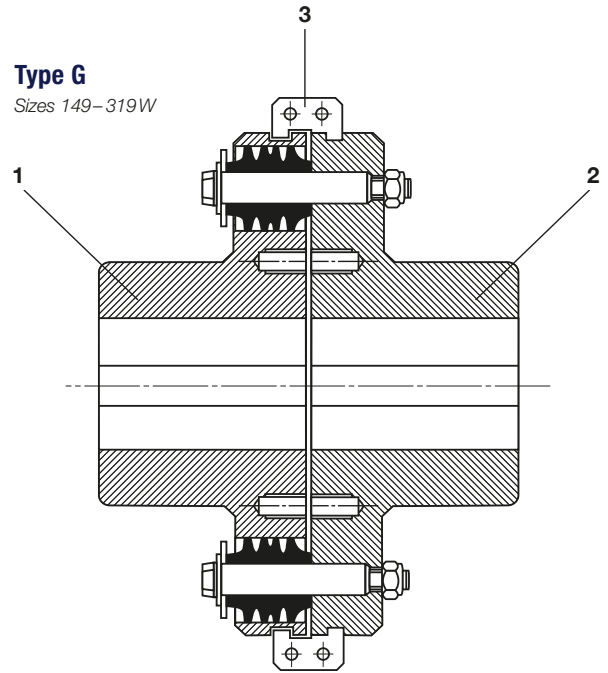

### Type E

The axially adjustable fixing ring 4 is attached to transmission bolt 3, set screw 5 and pipe nut 6. In addition, different to type N, the stop bolts 7 are attached to coupling part 1. After assembly of coupling parts 1 and 2, the desired axial clearance of the rotor can be adjusted by moving the stop bolts and the fixing ring. In this way it is possible to adapt the axial clearance of the rotor to the respective local conditions.

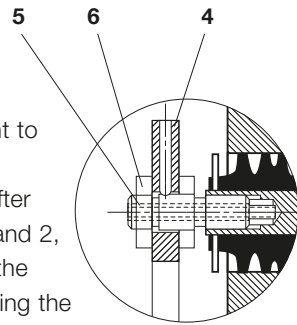

### Type E

Sizes 214–454

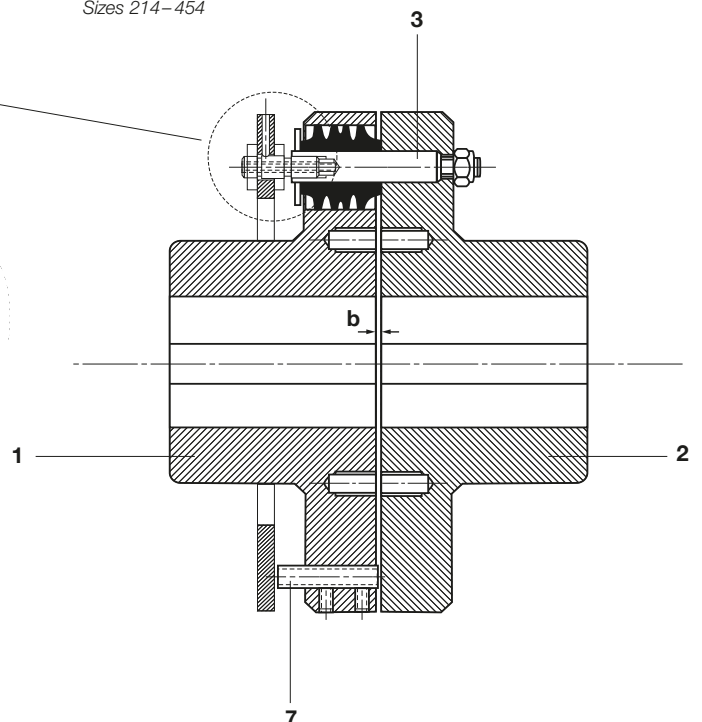

The main dimensions correspond to those of type N.

# Special Design

and Individual Solutions

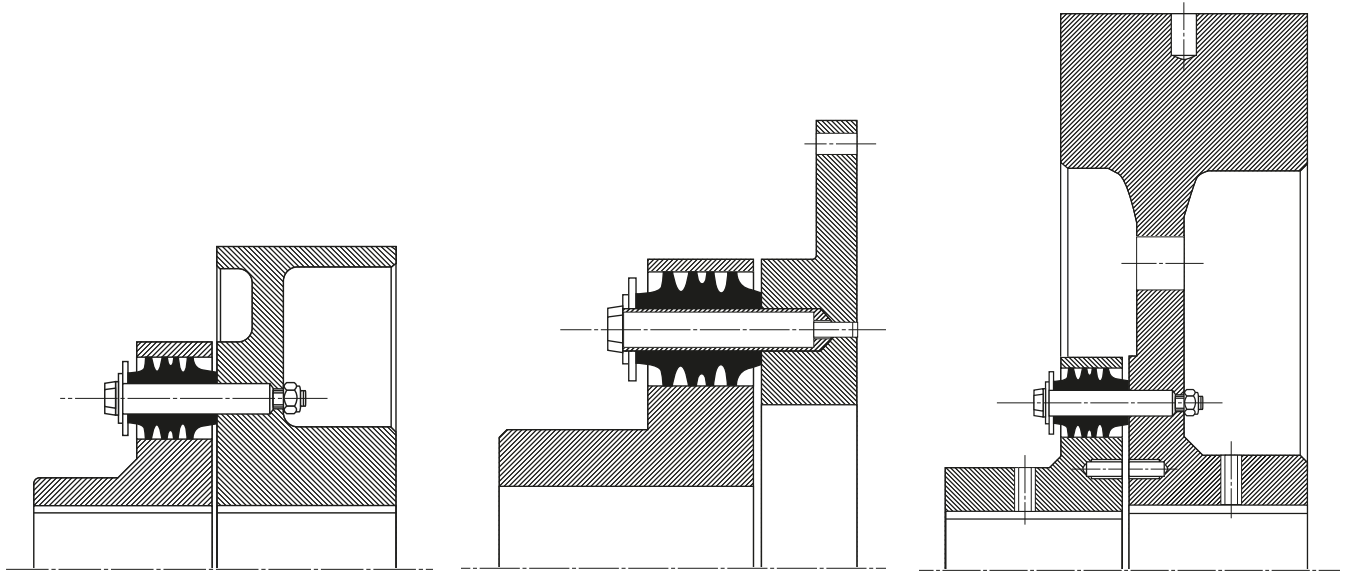

## ELCO-Couplings with integral brake drum

are available in the sizes and dimensions indicated on pages 16 and 17 and also in special sizes.

## ELCO-Couplings Type F-SAE

are especially designed for attachment to the flywheel flanges in accordance with SAE J 620 c. Data sheet RW-1058 is available upon request.

## ELCO-Couplings combined with flywheel

are delivered with the desired mass moment of inertia. Out of material stress reasons, the flywheel is always manufactured in combination with Part 2 (bolt part).

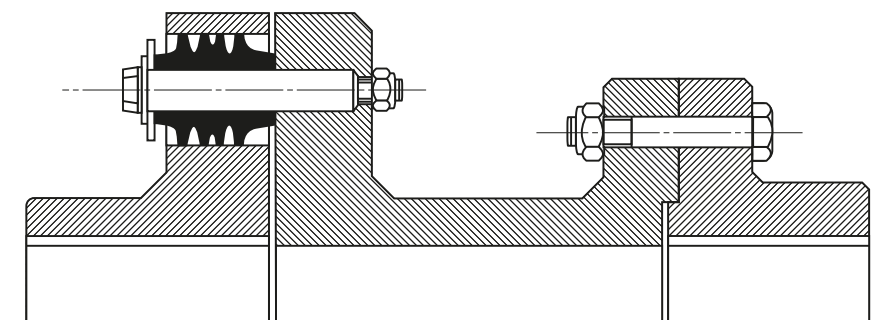

## ELCO-Couplings with extension piece

are used where a design-related distance must be bridged in axial direction (e.g. in rotary pumps for dismounting the sealing components). Dismounting of the transmission elements (bolts, profile sleeves...), of the fitting bolts and of the extension piece can be done without displacement of the coupled units.

If possible, the design dimensions are adapted to the requirements of the machine to be coupled.

Data sheet RW-1034 is available upon request.



Additional individual solutions are available upon request.

# Weights [kg]

Values refer to nominal diameter of the bores and the hub diameter, corresponding to the bores.

All values refer to steel as material of the couplings.

Flange 2: - including transmission components.

Type W: - flange 1 and flange 2 including their transmission components.

Coupling size	Nom. dia. [mm]	For all Types		Type N / W		Type B		Intermediate ring
		Flange 1	Flange 2	Flange 1 + 2	Flange 2 / 12	Flange 1 + 2 / 12		
018	10	0,93	1,1	2,03	—	—	—	
036		0,85	1,15	2,0	—	—	—	
044		1,1	1,5	2,6	—	—	—	
066	20	1,0	1,55	2,55	—	—	—	
098		1,4	2,8	4,2	—	—	—	
113		1,2	2,9	4,1	—	—	—	
123	40	2,1	3,6	5,7	—	—	—	
129		1,9	3,7	5,6	—	—	—	
149		3,6	5,9	9,5	10,2	13,8	0,4	
161	50	3,2	6,0	9,2	—	—	0,5	
184		6,5	9,5	16	15	21,5	0,5	
210		6,1	9,6	15,7	—	—	0,6	
214	70	10	15,5	25,5	25,8	35,8	0,7	
215		9,9	15,5	25,4	—	—	0,8	
222		18,5	26,0	44,5	44	63	1,0	
228	80	17	26,5	43,5	—	—	1,3	
231		27	37	64	55	82	1,3	
237		26	37	63	—	—	1,6	
247	100	37	55	91	83	120	2,1	
259 W		43	43	88	—	—	2,6	
271		55	73	128	108	163	2,6	
285 W	110	63	63	126	—	—	3,1	
311		87	116	203	170	257	3,5	
314 W		100	100	200	—	—	4,4	
316	140	118	154	272	236	354	4,4	
319 W		134	134	268	—	—	5,3	
324		146	224	370	350	496	7,4	
329 W	160	169	169	338	—	—	8,9	
335		215	300	515	470	685	8,9	
341 W		232	232	464	—	—	10,4	
353	200	346	455	807	660	1006	10,4	
378		397	518	915	—	—	—	
412		545	780	1325	—	—	—	
416	260	550	810	1360	—	—	—	
420		780	1050	1830	—	—	—	
426		1050	1460	2510	—	—	—	
432	320	1160	1660	2820	—	—	—	
443		1500	2060	3560	—	—	—	
454		2340	3150	5490	—	—	—	

For designs with an intermediate ring, the coupling weights are to be increased by the weight of the intermediate ring which is listed separately.

In case of separate calculation, the weight of the intermediate ring is to be added to that of flange 2 or flange 2/12

The weight of the intermediate ring refers to one set.

Type S		
Brake drum Flange 12 Ø [mm]	Width [mm]	[kg]
200	75	5,0
250	95	8,25
315	118	14,6
400	150	28,6
500	190	51
630	236	93
710	265	124
800	300	169

The weights of the coupling are the same as those of type N.

By adding the weights of the brake drum and of flange 2 of the ELCO-Coupling type N you obtain the weight of flange 2/12.

# Moments of inertia [kgm<sup>2</sup>]

Values refer to nominal diameter of the bores and the hub diameter, corresponding to the bores.

All values refer to steel as material of the couplings.

Flange 2: - including transmission components.

Type W: - flange 1 and flange 2 including their transmission components.

Coupling size	Nom. dia. [mm]	For all Types		Type N / W	Type B		Intermediate ring
		Flange 1	Flange 2	Flange 1 + 2	Flange 2 / 12	Flange 1 + 2 / 12	
018	10	0,00083	0,00096	0,00180	—	—	—
036		0,00075	0,00130	0,00205	—	—	—
044		0,0012	0,0017	0,0029	—	—	—
066	20	0,0012	0,0017	0,0029	—	—	—
098		0,0022	0,0041	0,0063	—	—	—
113	30	0,0018	0,0042	0,0060	—	—	—
123		0,0042	0,0069	0,0111	—	—	—
129		0,0037	0,0070	0,0107	—	—	—
149	50	0,012	0,017	0,028	0,0268	0,0376	0,0014
161		0,010	0,017	0,027	—	—	0,0017
184		0,025	0,038	0,062	0,0600	0,0852	0,0027
210	60	0,023	0,038	0,061	—	—	0,0032
214		0,054	0,086	0,140	0,145	0,1991	0,0051
215	70	0,053	0,085	0,139	—	—	0,0057
222		0,149	0,211	0,359	0,3525	0,5013	0,011
228		0,134	0,213	0,346	—	—	0,014
231	90	0,249	0,389	0,627	0,548	0,7977	0,018
237		0,237	0,391	0,628	—	—	0,022
247		0,459	0,662	1,121	0,993	1,452	0,035
259 W	100	0,562	0,562	1,125	—	—	0,043
271		0,794	1,092	1,886	1,700	2,494	0,058
285 W		0,957	0,957	1,915	—	—	0,069
311	120	1,653	2,571	4,224	3,650	5,303	0,101
314 W		2,080	2,080	4,160	—	—	0,126
316		2,809	4,357	7,166	6,350	9,159	0,170
319 W	140	3,530	3,530	7,060	—	—	0,204
324		4,552	7,920	12,472	12,100	16,652	0,341
329 W		6,019	6,019	12,038	—	—	0,409
335	180	8,190	13,510	21,700	20,800	28,990	0,574
341 W		10,420	10,420	20,840	—	—	0,669
353		18,800	29,300	48,100	41,800	60,600	0,904
378	220	29,800	49,100	78,900	—	—	—
412	240	51	88	138	—	—	—
416	260	60	115	175	—	—	—
420	280	102	178	280	—	—	—
426	300	157	277	434	—	—	—
432	320	190	356	546	—	—	—
443	350	292	538	830	—	—	—
454	400	588	812	1400	—	—	—

For designs with intermediate ring, the moment of inertia of the coupling is to be increased by the moment of inertia of the intermediate ring which is listed separately.

In case of separate calculation, the moment of inertia of the intermediate ring is to be added to that of flange 2 or flange 2/12.

The moment of inertia of the intermediate ring refers to one set.

Type S			The moments of inertia of the coupling are the same as those of type N.
Brake drum Flange 12 $\varnothing$ [mm]	Width [mm]	[kgm <sup>2</sup> ]	
200	75	0,0375	The moments of inertia of the coupling are the same as those of type N.
250	95	0,108	
315	118	0,278	
400	150	0,863	By adding the moments of inertia of the brake drum and of flange 2 of the ELCO-Coupling type N you obtain the moment of inertia of part 2/12.
500	190	2,450	
630	236	7,000	
710	265	11,63	
800	300	20,75	

# Spare Parts

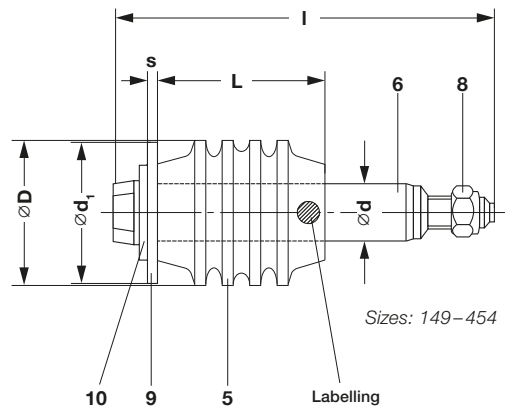
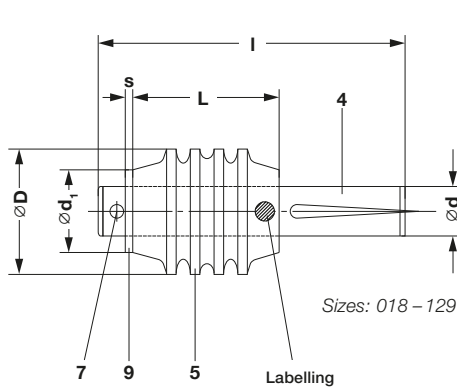

Size	Qty.	5 Sleeves		4 or 6 Transmitting pin				9 Washer		10 Circlip	7 Grooved pin	8 Nut
		D	L <sup>3)</sup>	d	l	l <sup>1)</sup>	l <sup>2)</sup>	d <sub>1</sub>	s			
018	2											
036	4											
044	4	19,6	25	8	51	—	—	13	1,5	—	Ø 2,5 x 12	—
066	6											
098	6											
113	8	24,6	30	10	62	62	—	16	1,5	—	Ø 3 x 16	—
123	8											
129	10											
149	8											
161	10	31,4	36,5	12,8	88	102	104	24	2	13 x 1	—	M 8
184	10											
210	12											
214	10	39,2	44,5	15,8	103,5	117,5	123,5	28	2,5	16 x 1	—	M 8
215	11											
222	8											
228	10	49,1	52,5	19,8	123,5	139	143,5	38	3	20 x 1,2	—	M 10
231	10											
237	12											
247	8					165						
259 W	10	62,1	62,5	24,8	147	—	172	48	3	25 x 1,2	—	M 12
271	10					165						
285 W	12					—						
311	8					200,5						
314 W	10	79	77,2	32,8	181,5	—	206,5	62	4	33 x 1,5	—	M 16
316	10					200,5						
319 W	12					—						
324	10					235						
329 W	12	98,7	93	40	213	—	243	76	4	40 x 1,75	—	M 20
335	12					235						
341 W	14					—						
353	10	123,5	113,5	50	255	—	285	92	4	50 x 2	—	M 24
378	14											
412	12	158,3	141,5	63	316,5	—	—	140	6	62 x 2	—	M 30
416	14											
420	16											
426	12											
432	14	198	176,5	80	395	—	—	175	6	80 x 2,5	—	M 36
443	16											
454	18											

Sleeve quality	Labelling
<b>U</b>	old = white / new = <b>U</b>
<b>W</b>	old = yellow / new = <b>W</b>
<b>V</b>	old = purple / new = <b>V</b>

Information on sleeve quality see page 4 + 5

1) Execution S 2) For execution with intermediate ring 3) Normal length (without preload)

# Distribution



## Sales offices

Australia  
Austria  
Belgium  
Brazil  
Canada  
Croatia  
Czech Republic  
Finland  
France  
GB and Ireland  
Hungary  
India  
Italy  
Japan  
Liechtenstein  
Luxembourg  
Mexico  
Netherlands  
Norway  
PR China  
Republic of Slovenia  
Slovak Republic  
South Africa  
South Korea  
Spain  
Switzerland  
USA

## Production and Distribution Centers <sup>1)</sup>

RENK Corporation  
304, Tucapau Road  
Duncan, S.C. 29334  
USA  
Phone: +1 864.433-0069  
Fax: +1 864.433-0636  
E-Mail: [bearings@renkusa.com](mailto:bearings@renkusa.com)

COFICAL RENK MANCAIS DO BRASIL  
LTDA. Rodovia BR-280 km 54  
CEP 89270-000 Guaramirim SC  
Santa Catarina, Brazil  
Phone: +55 47.3373-6400  
Fax: +55 47.3373-6499  
E-Mail: [info@renk.com.br](mailto:info@renk.com.br)

MAN Diesel & Turbo Japan Ltd.  
PMO Nihonbashi-Odemmacho  
Bldg10F 6-8 Nihonbashi-Odemmacho  
Chuo-ku, Tokyo 103-0011  
Japan  
Phone: +81 3.6667-2461  
Fax: +81 3.6667-2470  
E-Mail: [a.matsuda@renkjp.biz](mailto:a.matsuda@renkjp.biz)

OMEGA RENK BEARINGS PVT. LTD.  
Anand Nagar, Raisen Road  
Bhopal - 462 021  
India  
Phone: +91 755.5 28 45 61  
Fax: +91 755.275 16 26  
E-Mail: [info@omegarenk.com](mailto:info@omegarenk.com)  
Internet: [www.omegarenk.com](http://www.omegarenk.com)

<sup>1)</sup> Other countries are managed directly by RENK AG Hannover plant.

---

**RENK GmbH**

**Hannover plant**

Weltausstellungsallee 21

30539 Hannover

Germany

Phone: +49 (0) 511.86 01-0

Fax: +49 (0) 511.86 01-288

E-Mail: [info.hannover@renk.biz](mailto:info.hannover@renk.biz)

[www.renk-group.com](http://www.renk-group.com)